

Simba 1257

Technical specification

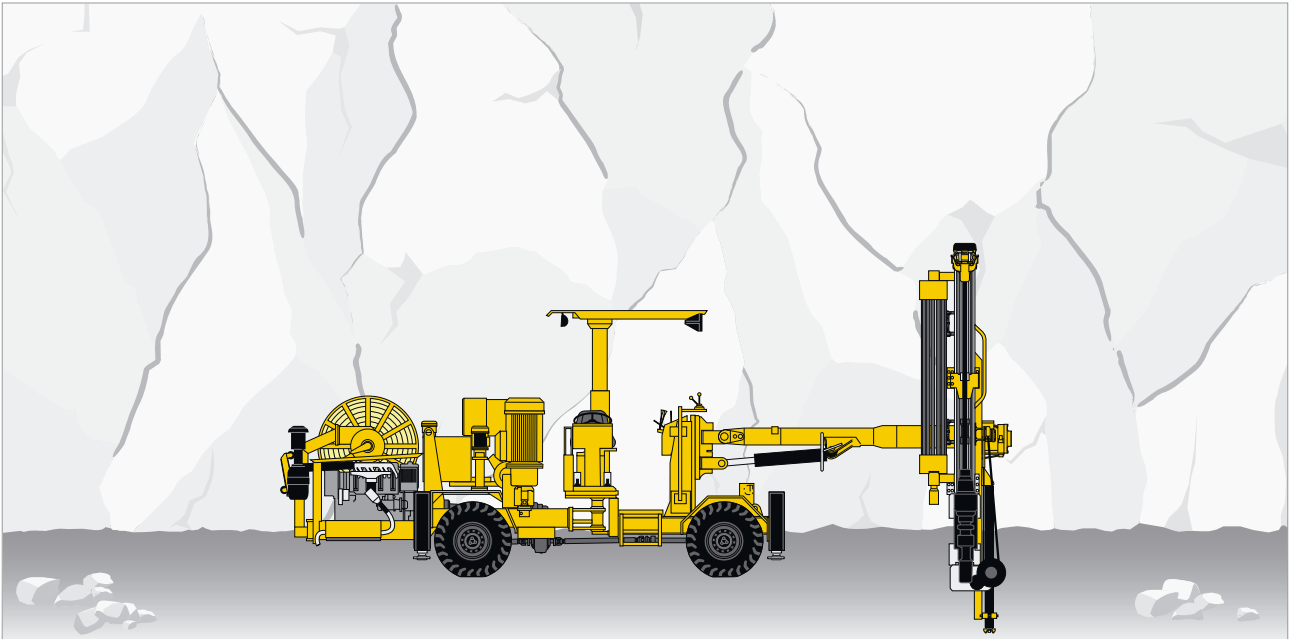

Production drilling rig adapted for small- to medium-sized drifts. Production drilling with tophammer rock drill in the hole range 51–89 mm. Boom-mounted drilling unit for optimized reach and flexibility.

Standard features

» Rock drill

- Atlas Copco COP 1800-series
- Dual-damping system for shock wave absorption and continuous rock contact for high penetration
- Lubricated and pressurized mating surfaces giving long service intervals
- Shank adapters suitable for the given hole range

» Drilling unit

- BMHP 6000-series heavy-duty aluminium hydraulic feed
- Front-mounted stinger
- Drill steel support for guidance during collaring and as support during manual rod handling

» Positioning unit

- BUT 32PD boom with mine-adapted, sturdy components
- Boom mounted drilling unit
- Accurate and smooth movements

» Control system

- Direct Control System (DCS)
- Rotation Pressure Controls Feed (RPCF)
- Anti-jamming system
- Angle reading instrument, ARI 1257

» Carrier

- Mine-adapted carrier for small- to medium-sized drifts with articulated steering and four-wheel drive

» General

- Operator panel mounted under canopy
- FOPS-approved protective roof
- Electrical cable reel
- Working lights on protective roof

Specifications

ROCK DRILL

COP 1838ME

Shank adapter	R32, T38, (T45*)
Hole diameter	51–89 mm
Impact power	18 kW
Impact rate	54 Hz
Hydraulic pressure, max.	230 bar
Rotation motors	Separate rotation
Rotation speed	0–210 rpm
Lub. air consump. (at 3 bar)	6 l/s
Water consumption	50 l/min
Weight	171 kg

*T45 gives 9 rods in carousel instead of 10

FEED

	BMH 6800	BMH 6804	BMH 6805	BMH 6806
Total length	3,141 mm	3,448 mm	3,753 mm	3,753 mm
Drill rod length	1,220 mm	1,525 mm	1,830 mm	1,830 mm
Total length with extractor	3,331 mm	3,655 mm	3,960 mm	3,960 mm

» Drilling unit

- Rod Handling System, RHS 10..... 10+1 rods
- Adaptable to 4', 5' and 6' rods
- Adaptable to R32, T38, (T45) drill rods
- Mechanized drilling up to 20 m

» Positioning system

- Boom BUT 32PD
- Feed extension..... 900 mm
- Boom extension..... 1,250 mm
- Stinger forward on feedBSJ 4-45
- Feed dump, drilling +24° forward and -79° backward
- Angle Reading Instrument, ARI 1257

» Control system

- Direct Control System, DCS
- Basic functions such as Rotation Pressure Controlled Feed (RPCF) and anti-jamming

» Power pack

- Hydraulic pump for percussion
- Hydraulic pump for rotation, positioning, feed
- Pumps unloaded at start
- System pressure, max..... 230 bar
- Hydraulic oil tank, volume..... 124 l
- Low oil level indicator and shut-down
- Oil temperature gauge on oil tank
- Electric oil filling pump
- Filtration, absolute..... 16 µm
- Oil filter indicator
- Water cooled oil cooler in stainless steel
- Mineral hydraulic oil

» Electrical system

- Total installed power..... 65 kW
- Main motor..... 55 kW
- Voltage..... 380–1,000 V
- Frequency..... 50–60 Hz
- Starting method..... star/delta (380–690 V)
- Electronic overload protection for electric motors
- Digital volt/amperage meter in electric cabinet
- Phase sequence indicator
- Earth fault indicator
- Battery charger
- Transformer..... 4 kVA
- Working lights, mounted on roof..... 2x500 W, 230 V
- Cable reel
- Limit switch for cable reel
- Manual spotlight, left side

» Air system

- Lubricated air for the rock drill
- Compressor..... Atlas Copco LE7
- Capacity at 5,400 rpm and 7 bar 12 l/s
- Air pressure gauge
- Adjustable flow/pressure
- Hole blowing kit with external air

» Water system

- Hydraulic driven water booster pump
- Capacity at 7 bar boost..... max 80 l/min
- Min water inlet pressure..... 2 bar
- Hydraulic drive, axial piston motor
- Water pressure gauge
- Water flow guard

» Carrier

- Engine..... Deutz F5L 912W
- Power rating at 2,300 rpm..... 52 kW (70 hp)
- Torque at 1,550 rpm 248 Nm
- Fixed seat for tramming, including safety belt
- Articulated steering..... ±41° steering angle
- Four-wheel drive
- FOPS-approved protective roof
- Hydrostatic power steering system
- Hydrodynamic transmission..... Clark 12000
- Front axle DANA 176
- Rear axle..... DANA 176, ±8° oscillation
- Automatic differential lock on front axle, limited slip
- Tyres..... 8.25 x R15
- Clearance outside axles..... 15°
- Hydraulic jacks, front..... 2 extendable
- Hydraulic jacks, rear..... 2
- Service brakes 2 separate circuits (hydraulically applied, fully enclosed wet disc brakes)
- Emergency and parking brakes..... SAHR
- Fuel tank, volume..... 60 l
- Electric system..... 24 V
- Batteries..... 2 x 70 Ah
- Tramming lights..... 8 x 70 W
- Illuminated stairs for platform
- Central lubrication system
- Silencer
- Catalyser
- Fire extinguisher
- Spirit levels
- Gradeability at max load on drive wheels..... 1:4
- Tramming speed on flat ground..... >10 km/h
- Tramming speed on incline 1:8..... >4 km/h
- Horn, beacon and reverse alarm

Specifications

DRILL STEEL

Rock drill	Hole diameter, mm	Drill rod	Shank adapter	Guide tube
COP 1838ME	51–64	R32 Speedrod	R32	N/A
COP 1838ME	64–76	T38 Speedrod	T38	TDS 56
COP 1838HE	76–89	(T45 Speedrod)	(T45)	TDS 64

Optional equipment

» Drilling system

- Water mist flushing, water oil cooler, external air supply
- Water mist flushing, air oil cooler, external air supply
- Rock drill lubrication surveillance system
- Big hole drilling kit
- Hole blowing kit with internal air
- COP 1838MEX, COP 1838HE, COP 1838HEX

» Positioning system

- Rig Alignment Laser RAL 650
- Stinger backward
- Thread lubrication kit
- Automatic lubrication for positioning/drilling system
- Central lubrication for positioning/drilling system

» Power pack

- Heater kit

» Carrier

- Fire suppression system ANSUL, manual
- Brake lights
- Outlet for communication radio, 12 V

» Electrical system

- Electrical cable on reel, H07RN-F
- Electrical cable on reel, Buxflex
- Plug PC4/PC5
- Socket PC4/PC5
- Switch gear
- Electrics according to local standards
- Working lights, 2x200 W, 24 V

» Miscellaneous

- Shelf for bits and tools
- Rod holder for extra drill rods
- Ni-Cr piston rods
- Manual lubrication kit
- Rig washing kit

Measurements

SIDE VIEW

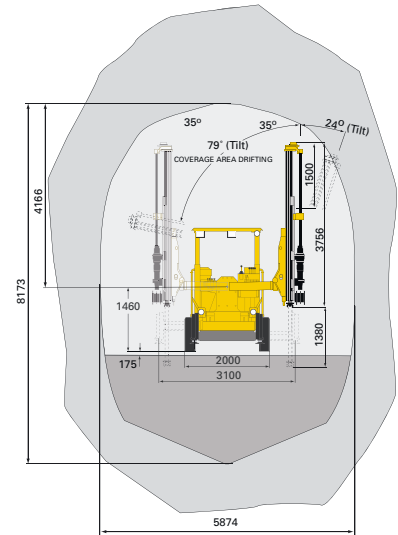
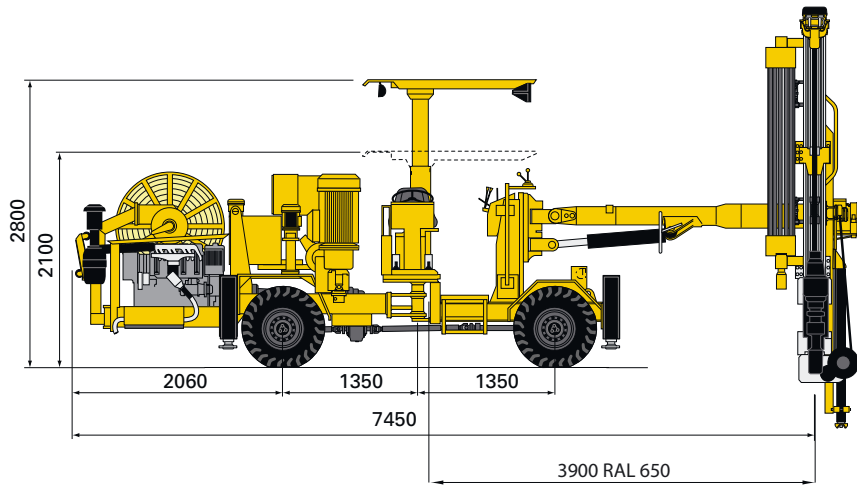

COVERAGE AREA

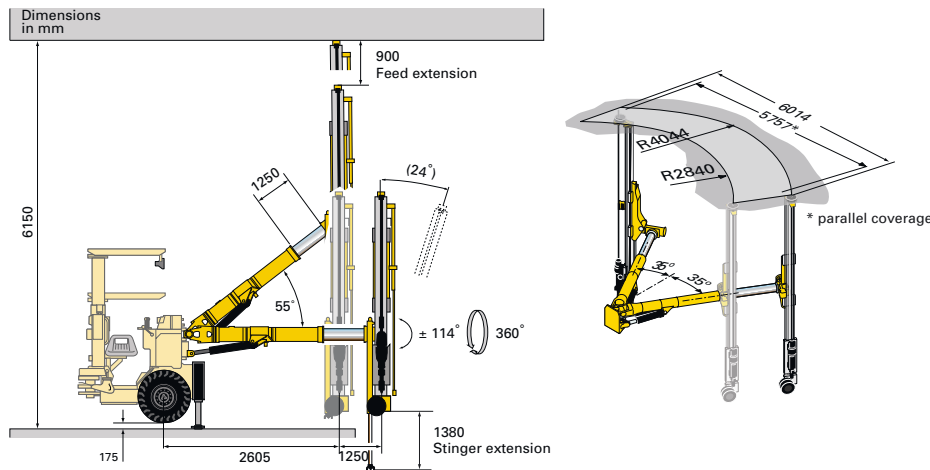

TURNING RADIUS		
depending on surface		
mm	Outer	4,900
	Inner	2,700

DIMENSIONS		
mm	Width	2,000
	Height tramming, roof down	2,100
	Height roof up	2,800
	Length tramming (with BHMP 214/215/216)	8,805*/9,112*/9,417*
	Ground clearance	335

*+200 mm with extractor

WEIGHT		
gross weight		
kg	Total	11,800
	Boom side	7,800
	Engine side	4,000

RECOMMENDED CABLE SIZE AND LENGTH				
Voltage	Type	Dimension, mm ²	Diameter, mm	Length, m
380–400 V	H07RN-F	4x50	38	40
380–400 V	Buflex	3x70+3G35	37	60
440–575 V	H07RN-F	4G35	38	60
440–575 V	Buflex	3x50+3G25	32	80
660–700 V	H07RN-F	4x25	34	70
660–700 V	Buflex	3x35+3G25	28	105
1,000 V	Buflex	3x35+3G10	28	105

G = Protection yellow/green
Recommendations are given for surrounding temperature of 40° C.

© Copyright 2008, Atlas Copco Rock Drills AB, Örebro, Sweden. All product names in this publication are trademarks of Atlas Copco. Any unauthorized use or copying of the contents or any part thereof is prohibited. Illustrations and photos in this brochure may show equipment with optional extras. Specifications and equipment are subjects to change without notice. Consult your Atlas Copco Customer Center for specific information.

9851 2295 01 a 04/2008

